



Government Girls' Polytechnic, Bilaspur

Name of the Lab: **Electronics Lab**

Practical: **Power Electronics Lab**

Class : **4th Semester (ET&T)**

Teachers Assessment:10 End Semester Examination:50

EXPERIMENT No- 1

OBJECTIVE: - Performance of Thyristor.

EQUIPMENT REQUIRED: - Trainer kit, Patch cards, Multimeters.

THEORY: - In power electronics the thyristor is the most common and popular family of switching devices. According to constructions, the numbers of semiconductor layer of thyristor family member are nearly similar but their position arrangements are different and also the terminals are connected in different positions. For this they have shown different characteristics. Some of the family members are bidirectional that is they conduct current in both terminals and have no polarity limitations and use to switch in the heavy ac load, otherwise unidirectional member conduct current in only one direction and use mostly in rectification of ac and also switch. Usually four layers and also five layers semiconductor devices are called the thyristor. According to their construction they have at least two terminals to maximum four terminals. Specifically the five layer members (TRIAC, DIAC) of thyristor family are used their four semiconductor layer in the state of conduction.

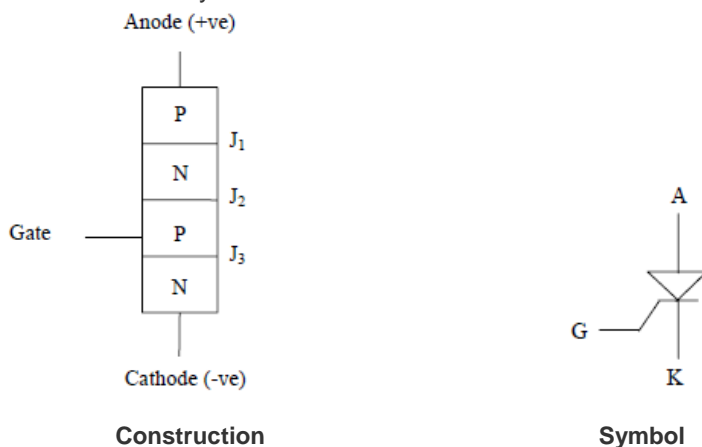

CIRCUIT DIAGRAM:-

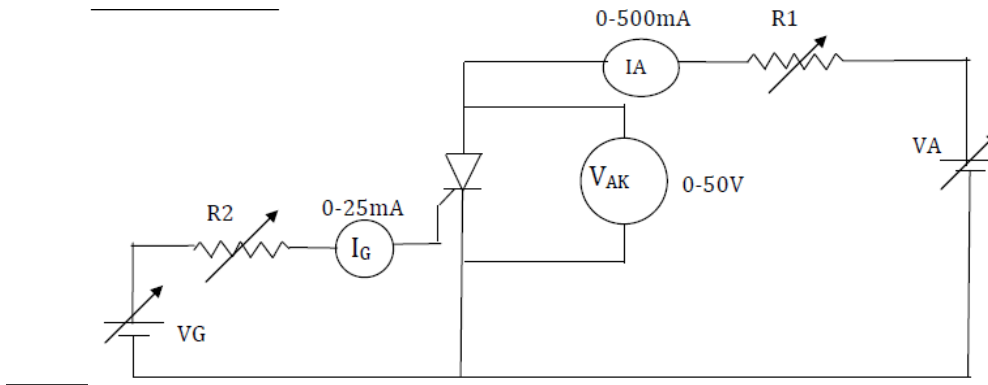

Circuit diagram for V-I characteristics of thyristor.

PROCEDURE:-

V - I Characteristics:

1. Make the connections as given in the circuit diagram including meters for SCR 1.
2. Now switch ON the mains supply to the unit and initially keep VA & VG at minimum.
3. Set load potentiometer R1 in the minimum position. Adjust IG to the value found in procedure 1.
4. Slowly vary VA and note down Vak and IA readings for every 5 Volts and entered the readings in the tabular column. Further vary VA till SCR conducts, this can be noticed by sudden drop of Vak and rise of IA readings note down this readings and tabulate. Keep multi meter in mili-volts range and connect across VA terminals. Note down the variation of IA for small variations in VA.
5. Draw the graph of Vak v/s IA. Repeat the same for $I_G = I_{G2} / I_{G3}$ and draw the graph.

To find latching current:

1. Apply about 20 V between Anode and Cathode by varying VA. Keep the load potentiometer R1 at minimum position. The device must be in the OFF state with gate open.

2. Gradually increase Gate voltage - V_G till the device turns ON. This is the minimum gate current (I_{gmin}) required to turn ON the device.
3. Adjust the gate voltage to a slightly higher.
4. Set the load potentiometer at the maximum resistance position. The device should come to OFF state, otherwise decrease V_A till the device comes to OFF state. The gate voltage should be kept constant in this experiment.
5. By varying R_1 , gradually increase load current I_A in steps. Open and close the Gate voltage V_G switch after each step. If the anode current is greater than the latching current of the device, the device stays on even after the gate switch is opened. Otherwise the device goes into blocking mode as soon as the gate switch is opened. Note the latching current.
6. Obtain the more accurate value of the latching current by taking small steps of I_A near the latching current value.

To find holding current:

1. Increase the load current from the latching current level by load pot R_1 or V_A .
2. Open the gate switch permanently. The Thyristor must be fully ON.
3. Now start reducing the load current gradually by adjusting R_1 . If the SCR does not turn OFF even after the R_1 at maximum position, then reduce V_A . Observe when the device goes to Blocking mode. The load current through the device at this instant is the holding current of the device.
4. Repeat the steps again to accurately get the I_h . Normally $I_h < I_L$.
5. Repeat the same procedure for other SCR - SCR 2. Note down the different ratings of both the devices.

OBSERVATION TABLE:-

a) V-I Characteristics Reading

Sl. No	IG = IG1 = mA		IG = IG2 = mA	
	V AK	IA	V AK	IA
1.				
2.				
3.				
4.				
5.				
6.				
7.				
8.				
9.				
10.				

- b) $I_G = \underline{\hspace{2cm}}$ mA
 c) Latching Current $I_L = \underline{\hspace{2cm}}$ mA
 d) Holding Current $I_h = \underline{\hspace{2cm}}$ mA

RESULT:- Static characteristics of thyristor are determined.

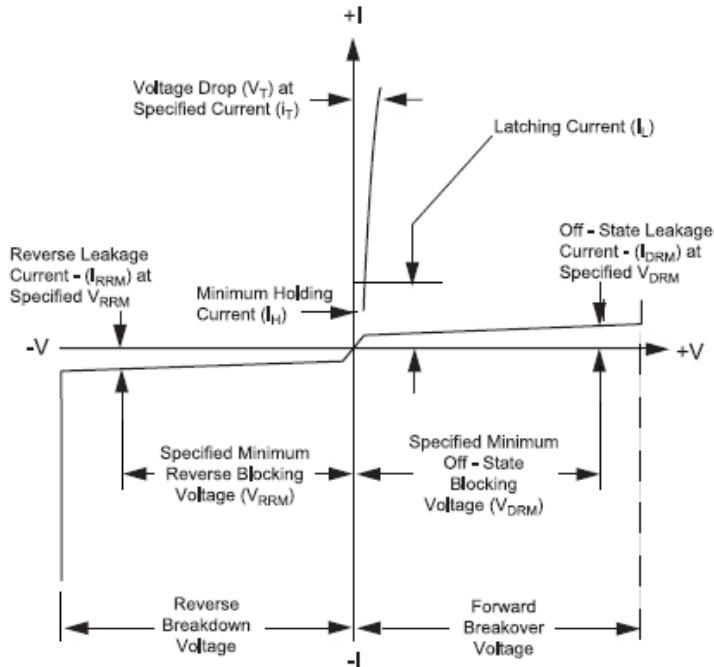

- PRECAUTIONS: -**
- 1) All the connection should be tight.
 - 2) Ammeter is always connected in series in the circuit while voltmeter is parallel to the conductor.
 - 3) The electrical current should not flow the circuit for long time, Otherwise its temperature will increase and the result will be affected.
 - 4) It should be care that the values of the components of the circuit is does not exceed to their ratings (maximum value).
 - 5) Before the circuit connection it should be check out working condition of all the Component.

EXPERIMENT No- 2

OBJECTIVE: - Performance of DIAC.

EQUIPMENT REQUIRED: - Trainer kit, Patch cards, Multimeters.

THEORY:- The other bidirectional operated member of thyristor family is DIAC or diode for alternating current or bilateral diode switch. The DIAC is a five layers and contains two terminal, anode A1 (or main terminal MT1) and anode A2 (or main terminal MT2) like a TRIAC just without a gate terminal. The DIAC construction is such that in conduction state it uses its two different four layers for each polarity changes of the terminal.

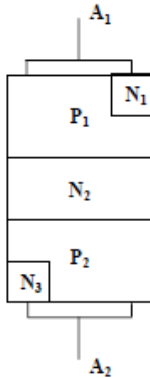

Construction of DIAC

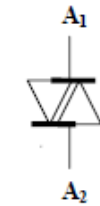

Symbol of DIAC

CIRCUIT DIAGRAM:-

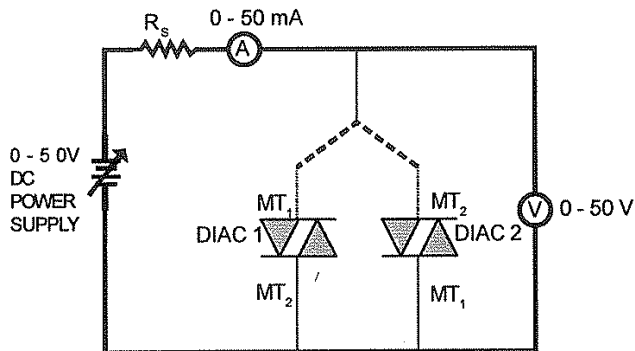

Circuit diagram for V-I characteristics of DAIC.

PROCEDURE:-

1. Connect the milliammeter, DIAC, Voltmeter to the circuit.
2. Switch ON the power supply.
3. Increase supply voltage in steps, note the corresponding currents and voltages for each step.
4. Plot graph of VI characteristics.
5. Reverse the Terminal of Diac. Increase supply voltage in steps, note the corresponding currents and voltages for each step.
6. Plot graph of VI characteristics.

OBSERVATION TABLE:-

Reading for voltage and current MT ₁ is +ve and MT ₂ is -ve	
O/P voltage (V)	Current (mA)

Reading for voltage and current MT ₂ is +ve and MT ₁ is -ve	
O/P voltage (V)	Current (mA)

RESULT:- Static characteristics of DIAC are determined.

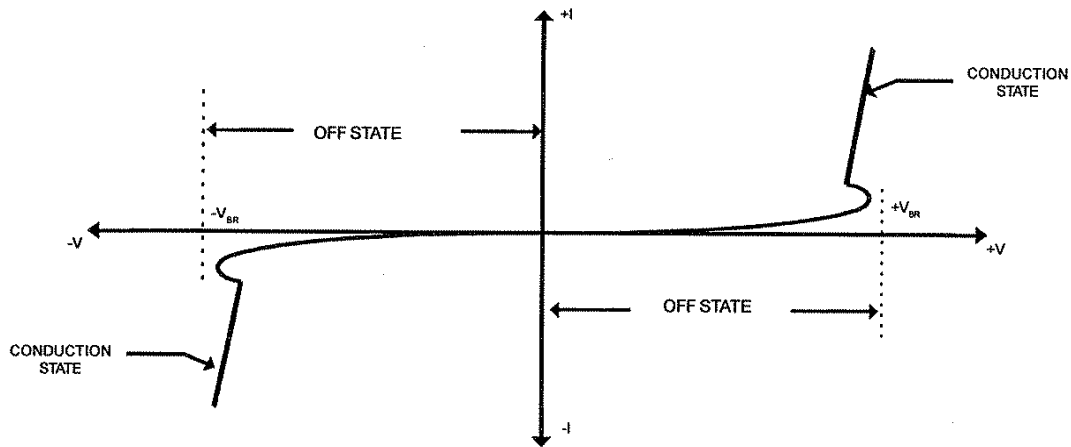

- PRECAUTIONS:** -
- 1) All the connection should be tight.
 - 2) Ammeter is always connected in series in the circuit while voltmeter is parallel to the conductor.
 - 3) The electrical current should not flow the circuit for long time, Otherwise its temperature will increase and the result will be affected.
 - 4) It should be care that the values of the components of the circuit is does not exceed to their ratings (maximum value).
 - 5) Before the circuit connection it should be check out working condition of all the Component.

EXPERIMENT No- 3

OBJECTIVE: - Frequency calculation of pulse in UJT relaxation oscillator.

EQUIPMENT REQUIRED: - UJT, resistance box, decade condenser box, variable d.c. power supply, C.R.O. and connecting terminals.

THEORY:- The UJT has negative resistance characteristic, because of this character the UJT provides trigger pulse. Any one of the three terminals can be taken for triggering pulse. The UJT can be used as relaxation oscillator i.e. it produces non-sinusoidal waves.

First the capacitor 'C' starts charging through the resistor R when V_{BB} is switched on. During the charging of the capacitor, the voltage across it increases exponentially until it reaches to the peak point voltage V_P. Up to now, the UJT is in off state, i.e. no conducting state at which R_{B1} value is high. When the voltage across the capacitor reaches to peak point voltage (V_P) then, UJT comes into conducting state as the junction is forward biased and R_{B1} falls to low value (50_). Then the capacitor 'C' quickly discharges through UJT that means the discharging time is very less as the capacitor discharges through the low resistance UJT. When the voltage across the capacitor decreases to valley point voltage (V_V) then the UJT shifts to off state and once again the capacitor gets charged through the resistor R and this process is repeated. This generates saw-tooth wave form

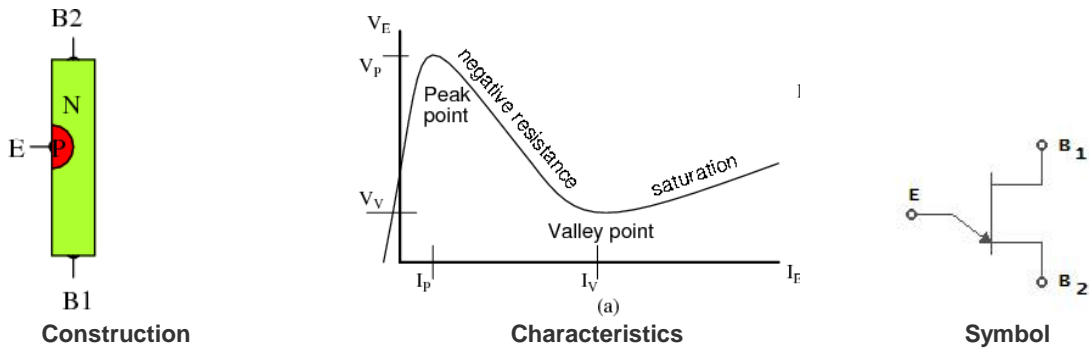

Formula: - Frequency of oscillator

$$f = \frac{1}{2.303 RC \log_{10} \left(\frac{1}{1-\eta} \right)} \text{ Hz}$$

Where R = Resistance of the resistor (Ω)
C = Capacity of the condenser (F)
 η = Intrinsic stand off ratio = 0.6

CIRCUIT DIAGRAM:-

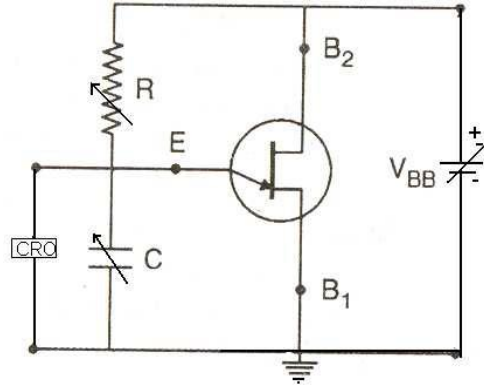

- PROCEDURE:** - 1) Connect the circuit as shown in Fig and apply a fixed voltage V_{BB} (5V to 10V) between the two bases B_1 and B_2 .
- 2) As the Y – plates of CRO is connected across the condenser a saw tooth wave form is observed on its screen when the power is switch on.
 - 3) Adjust of voltage sensitivity band switch of Y-plates and time base band switch X-plates such that at least one or two waves displayed in the screen.
 - 4) Now note the horizontal length(l) between two successive peaks, in the table. When this horizontal length (l) is multiplied by the time base(t) i.e. sec/div , we get the time-period(T).
 - 5) The reciprocal of the time-period($1/T$) gives the frequency(f). This is the experimental value.
 - 6) Note the values of resistance R and capacitance C of those connected in the circuit and take the intrinsic stand off ratio η as 0.6, substitute these values in the above formula and find the frequency. This is the theoretical value. Compare the theoretical and experimental frequencies. Repeat the experiment by changing the values of R or C or both.

OBSERVATION TABLE:-

$$\eta = 0.6$$

S. No.	R Ω	C F	Measurement of time period			Frequency	
			Horizontal length(l) div.	Time base (t) sec/div	T = $l \times t$ Sec.	Experimental $f = 1/T$	Theoretical $f = \frac{1}{2.303 RC \log_{10} \left(\frac{1}{1-\eta} \right)}$ Hz

RESULT: - Saw-tooth wave form across the capacitor which can be viewed on the CRO Screen.

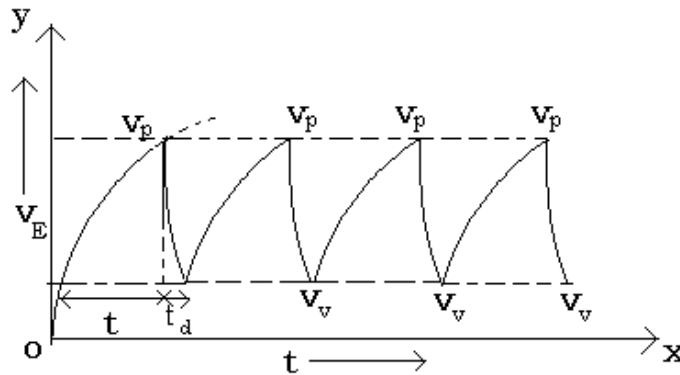

- PRECAUTIONS:** -
- 1) The continuity of the connecting terminals should be checked before going to connect the circuit.
 - 2) Identify the two bases and emitter of UJT and connect properly.
 - 3) The power supply should be 'on' only when the observations are taken.
 - 4) Measure the horizontal length of the wave with out any error.

EXPERIMENT No- 4

OBJECTIVE: - a) Performance of TRIAC
b) Application of TRIAC in AC loads control.

EQUIPMENT REQUIRED: - a) Trainer kit, Patch cards, Multimeters.
b) Experimental set up, voltmeter (0- 300V),
Ammeter (0 – 3 A), 185 ohm rheostat, inductance coil, 0.1 ohm std.
Resistance, Dual trace oscilloscope

THEORY: - TRIAC is one of the bidirectional devices of thyristor family. TRIAC have five layer and three terminals, the name TRIAC comes from its three electrodes (terminals) shown in fig9. It has no cathode terminal, one of the three is gate and the others are A_1 (MT1 i.e. main terminal) and A_2 (MT2) as it conducts by terminal. Triac can be triggered with either positive or negative gate pulses when the anode terminal potentials are positive or negative respectively. The five layers TRIAC can be divided into two halves one is SCR1 and other is SCR2 connected in parallel of opposite polarity i.e. four transistor as each SCR consist of two transistor.

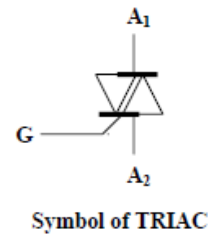
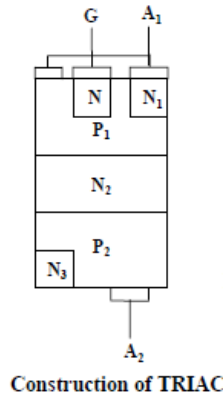

CIRCUIT DIAGRAM: -

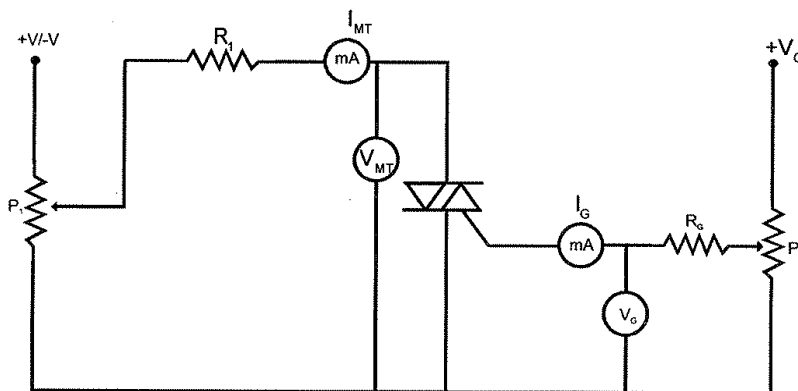

(a) Circuit diagram for V-I characteristics of TRIAC

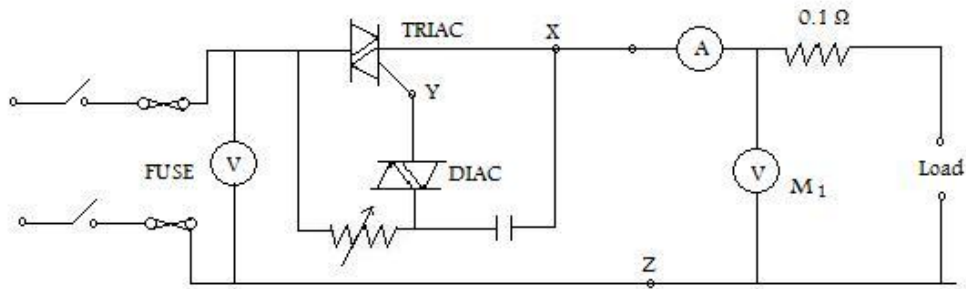

(b) Circuit diagram for triggering of TRIAC in different AC loads.

PROCEDURE: - For circuit diagram (a)

- 1) Make connections as per the circuit diagram.
- 2) Rotate potentiometers P_1 and P_2 for minimum resistance.
- 3) Switch on the power supply.
- 4) Put the switch towards +V.
- 5) Vary potentiometer P_2 to set gate current I_G to a lower value.
- 6) Increase voltage V_{MT} gradually by varying potentiometer P_1 .
- 7) Observe the current in ammeter 1. It will show zero current in initial stage.
- 8) Try various values of gate current. Vary voltage by P_1 and note down current I_{MT} .
- 9) Note down voltage V_{MT} and corresponding current I_{MT} after firing of TRIAC
- 10) Note down readings in table 1
- 11) Rotate potentiometer P_1 fully counterclockwise
- 12) Put the switch towards -V and repeat from step 3 and note down the readings in observation table 2.
- 13) Plot the graph of V_{MT} versus I_{MT} for the reading in both tables.

For circuit diagram (b)

1. Connect the 185 ohm rheostat between L_1 and L_2 . Set the potentiometer R on the panel to extreme ccw. Position (R is maximum). Connect the Input to a 230 v ac supply via a DPST switch.
2. Clip GND of oscilloscope probe to point x. The two line terminals are connected to Z and Y.
3. Set the oscilloscope to CHOP mode and observe the load voltage (inverted) in one trace and the gate cathode voltage in the other. Vary the resistance R and observe variation in the phase shift of the trigger pulses. Trace a typical display (invert the first display if y-invert is available on the oscilloscope.)

Resistive load.

1. With the same circuit as in A, plot trace xz for several values of the Display angle ' α '. Measure off ' α ' from the oscilloscope display. Note also the readings of the meters. Tabulate

Inductive load.

Connect the inductance across terminals L_1 and L_2 with ' α ' maximum, switch on the supply. Observe the load voltage and current waveforms for several values of the delay angle. (GND to x, line₁ to z and line₂ to L_1). Tabulate the readings of the meter and the calculated value of $V_{AC\ OUT}$ as in the last table. Switch off after observations for minimum values of delay angle have been noted.

OBSERVATION TABLE:-

Sr. No.	Voltage V_{MT}	Current I_{MT} at constant value of Gate current when switch is towards +V	
		$I_G = \text{-----mA}$	$I_G = \text{-----mA}$
1			
2			
3			
4			
5			

(a)Observation table for V-I characteristics of TRAIC

$V_{AC\ IN}$	$V_{AC\ OUT}$ (measured)	$V_{AC\ OUT}$ (calculated)

(b) Observation table for triggering of TRIAC in different AC loads.

RESULT:- (a) Static characteristics of TRIAC are determined.

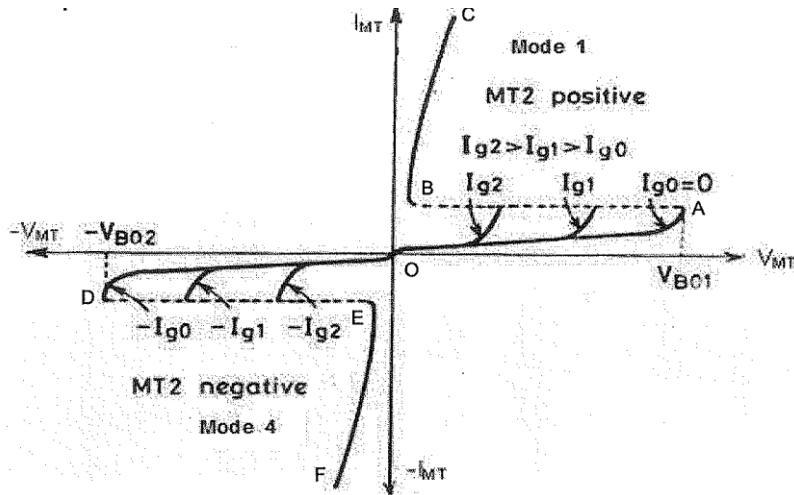

(b) The input and output waveforms are observed. When used to control AC power to a load, TRIACs are often accompanied by DIACs connected in series with their gate terminals. The DIAC helps the TRIAC fire more symmetrically (more consistently from one polarity to another).

PRECAUTIONS: - 1) All the connection should be tight.

- 2) Ammeter is always connected in series in the circuit while voltmeter is parallel to the conductor.
- 3) The electrical current should not flow the circuit for long time, Otherwise its temperature will increase and the result will be affected.
- 4) It should be care that the values of the components of the circuit is does not exceed to their ratings (maximum value).
- 5) Before the circuit connection it should be check out working condition of all the Component.

EXPERIMENT No- 5

OBJECTIVE: - a) Performance of IGBT.
b) Performance of GTO.

EQUIPMENT REQUIRED: - a) External meters, Connecting wires, IGBT/MOSFET module.
b) External meters, Connecting wires, GTO module.

THEORY:- (a) IGBT:- The insulated gate bipolar transistor or IGBT is a three-terminal power semiconductor device, noted for high efficiency and fast switching. The structure is very similar to that of a vertically diffused MOSFET featuring a double diffusion of a p-type region and an n-type region. An inversion layer can be formed under the gate by applying the correct voltage to the gate contact as with a MOSFET. The main difference is the use of a p⁺ substrate layer for the drain. The effect is to change this into a bipolar device as this p-type region injects holes into the n-type drift region. Blocking Operation: The on/off state of the device is controlled, as in a MOSFET, by the gate voltage V_G . If the voltage applied to the gate contact, with respect to the emitter, is less than the threshold voltage V_{th} then no MOSFET inversion layer is created and the device is turned off. When this is the case, any applied forward voltage will fall across the reversed biased junction J2. The only current to flow will be a small leakage current.

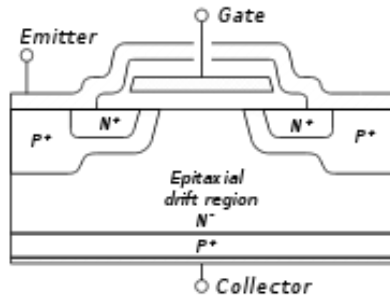

C



Symbol

(b)GTO: - A gate turn-off thyristor (GTO) is a special type of thyristor, a high-power semiconductor device. GTOs, as opposed to normal thyristors, are fully controllable switches which can be turned on and off by their GATE lead. Turn on is accomplished by a "positive current" pulse between the gate and cathode terminals. As the gate-cathode behaves like PN junction, there will be some relatively small voltage between the terminals. The turn on phenomenon in GTO is however, not as reliable as an SCR (thyristor) and small positive gate current must be maintained even after turn on to improve reliability. Turn off is accomplished by a "negative voltage" pulse between the gate and cathode terminals. Some of the forward current is used to induce a cathode-gate voltage which in turn induces the forward current to fall and the GTO will switch off (transitioning to the 'blocking' state). GTO thyristors suffer from long switch off times, whereby after the forward current falls, there is a long tail time where residual current continues to flow until all remaining charge from the device is taken away.

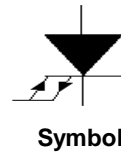
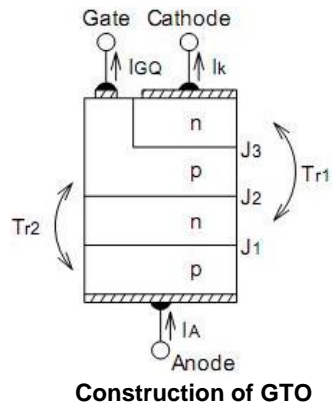

CIRCUIT DIAGRAM: -

1.

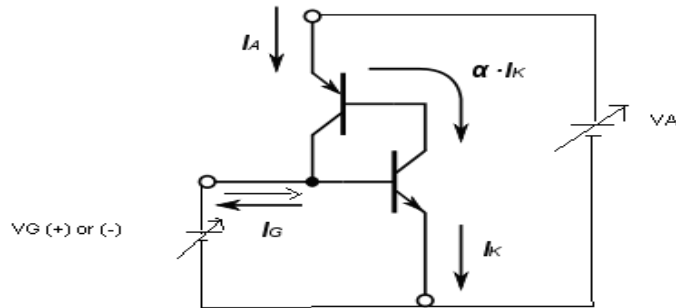
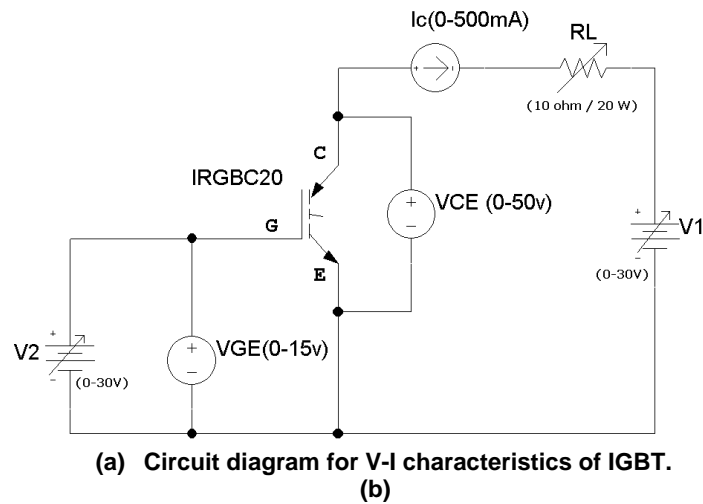

PROCEDURE: - (a) For Collector Characteristics of IGBT:-

1. Connections are made as shown in the circuit diagram.
2. Initially set V2 to $V_{GE1} = 5 \text{ v}$ (slightly more than threshold voltage)
3. Slowly vary V1 and note down I_C and V_{CE} .
4. For particular value of V_{GE} there is pinch off voltage between collector and emitter.
5. Repeat the experiment for different values of V_{GE} and I_C v/s V_{CE} .
6. Draw the graph of I_C v/s V_{CE} for different values of V_{GE} .

(b) For GTO performance:-

1. Connections are made as shown in the circuit diagram.
2. Set the voltage between anode and cathode as anode is made positive with respect to cathode.
3. Set the voltage between gate and cathode as gate is made positive with respect to cathode for turn on the GTO.
4. Note the different values for V_A and I_C and make gate current constant (at threshold).
5. Draw the graph between V_A and I_C .
6. Set the voltage between gate and cathode as gate is made negative with respect to cathode for turn off the GTO.
7. Note the different values for V_A and I_C and make negative gate current constant (at threshold).
8. Draw the graph between V_A and I_C .(dynamic characteristics)

OBSERVATION TABLE:- (a) For Collector Characteristics:-

S.no	$V_{GE} =$		$V_{GE} =$	
	$V_{CE} =$	$I_C =$	$V_{CE} =$	$I_C =$
1				
2				
3				
4				
5				

(b)For GTO performance:-

S.no	For Turn on GTO		For Turn off GTO	
	Positive $I_g =$	negative $I_g =$		
	$V_C =$	$I_C =$	$V_C =$	$I_C =$
1				
2				
3				
4				
5				

RESULT:- (a) For Collector Characteristics:- Static characteristics are determined.

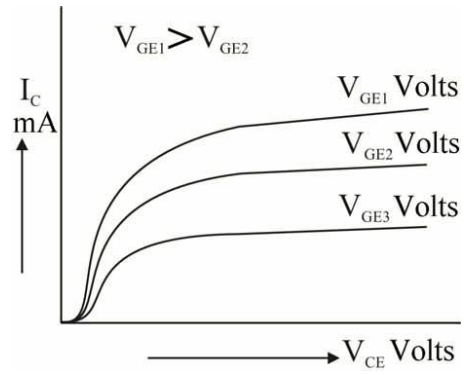

(b) For GTO performance: - The static characteristics of the GTO are same as SCR's.

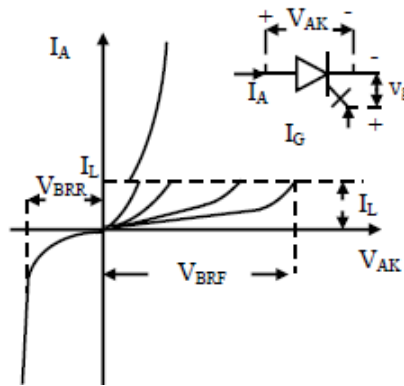

Switching or dynamic characteristics of GTO

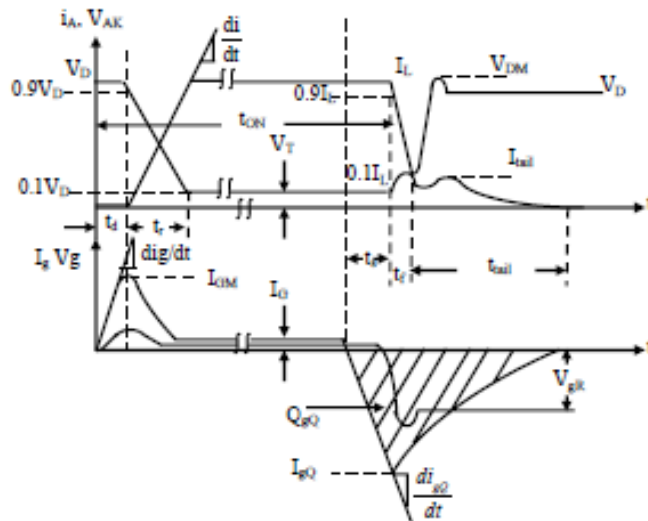

- PRECAUTIONS:** -
- 1) All the connection should be tight.
 - 2) Ammeter is always connected in series in the circuit while voltmeter is parallel to the conductor.
 - 3) The electrical current should not flow the circuit for long time, Otherwise its temperature will increase and the result will be affected.
 - 4) It should be care that the values of the components of the circuit is does not exceed to their ratings (maximum value).
 - 5) Before the circuit connection it should be check out working condition of all the Component.

14

15

16

17

EXPERIMENT No- 6

OBJECTIVE: - Study of Relaxation oscillator circuit using PUT.

EQUIPMENT REQUIRED: - PUT, resistance box, decade condenser box, variable d.c. power supply, C.R.O. and connecting terminals.

THEORY:- The programmable unijunction transistor (PUT) is not a unijunction transistor at all. The fact that the V-I characteristics and applications of both are similar prompted the choice of labels. It is also a four-layer P-N-P-N solid-state device with a gate connected directly to the sandwiched N-type layer. The basic structure, schematic symbol and the basic biasing arrangement of PUT are shown in figures respectively. As the symbol indicates, it is essentially an SCR with a control mechanism that permits a duplication of the characteristics of the typical SCR. The term “**programmable**” is applied because the inter base resistance R_{BB} , the intrinsic stand-off ratio η and peak-point voltage V_P , as defined in UJT can be programmed to any desired values through external resistors R_B and R_{B2} and the supply voltage V_{BB} . From figure we see that by voltage divider rule when $I_G = 0$,

$$V_G = (R_{B1} / R_{B1} + R_{B2}) V_{BB} = \eta V_{BB}$$

Gate connected to the junction of external resistors R_B and R_B . The four-layer construction shown in figure indicates that the anode-gate junction is forward biased when the anode becomes positive with respect to gate. When this occurs, the device is turned on. The anode-to-cathode voltage V_{AK} then drops to a low level, and the device conducts heavily until the input voltage become too low to sustain conduction. It is seen that this action stimulates the performance of a UJT. The anode of the device acts as the emitter of UJT.

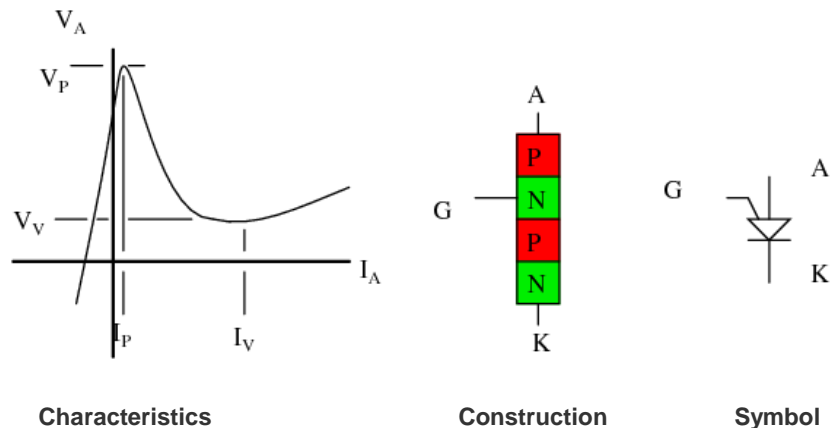

Formula: - Frequency of oscillator

$$f = \frac{1}{2.303 RC \log_{10} \left(\frac{1}{1-\eta} \right)} \text{ Hz}$$

Where R = Resistance of the resistor (Ω)
 C = Capacity of the condenser (F)
 η = Intrinsic stand off ratio = 0.6

CIRCUIT DIAGRAM:-

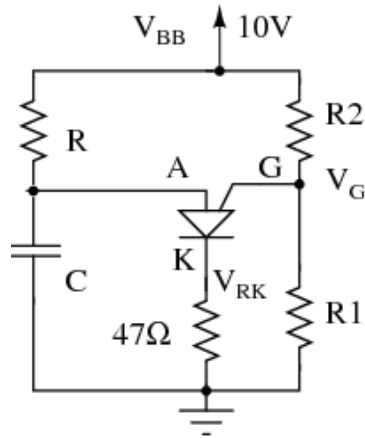

PROCEDURE: -1) PUT, because of its superiority over UJT, replaces UJT. One popular application of PUT is in the relaxation oscillate.

2) The instant the supply V_{BB} is switched on, the capacitor starts charging toward V_{BB} volts, since there is no anode current at this point.

3) The instant the voltage across the capacitor equals V_P , the device fires and anode current $I_A = I_P$ is established through the PUT.

5) As soon as the device fires, the capacitor starts discharging rapidly through the low on-resistance of the PUT and R_K . Consequently, a voltage spike is produced across R_K during the discharge.

6) As soon as the capacitor C gets discharged, the PUT turns off and the charging cycle starts all over again as narrated above.

OBSERVATION TABLE:-

$$\eta = 0.6$$

S. No.	R Ω	C F	Measurement of time period			Frequency	
			Horizontal length(l) div.	Time base (t) sec/div	T = lxt Sec.	Experimental $f = 1/T$	Theoretical $f = \frac{1}{2.303 RC \log_{10}(\frac{1}{1-\eta})}$ Hz

RESULT: - Saw-tooth wave form across the capacitor which can be viewed on the CRO Screen.

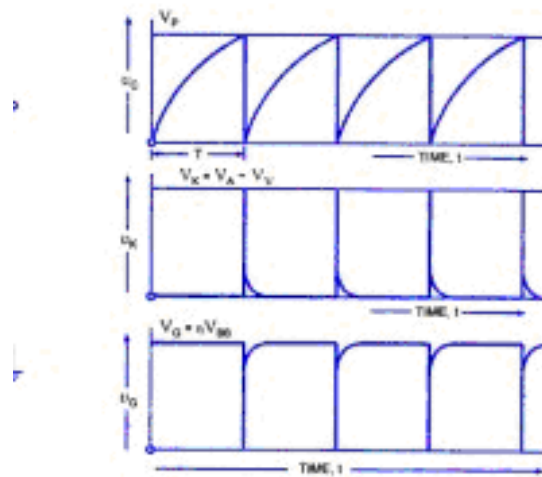

Voltage Waveforms For PUT Oscillator

PUT Relaxation Oscillator

- PRECAUTIONS:** -
- 1) The continuity of the connecting terminals should be checked before going to connect the circuit.
 - 2) Identify the two bases and emitter of PUT and connect properly.
 - 3) The power supply should be 'on' only when the observations are taken.
 - 4) Measure the horizontal length of the wave with out any error.

EXPERIMENT No- 7

OBJECTIVE: - Design of snubber circuit.

EQUIPMENT REQUIRED: - Thyristor, supply, resistance, capacitor, etc.

THEORY:- A snubber circuit consists of a series combination of resistance R_s and capacitance C_s in parallel with the thyristor. Strictly speaking, a capacitor C_s in parallel with the device is sufficient to prevent unwanted dv/dt triggering of the SCR. When switch S is closed, a sudden voltage appears across the circuit. Capacitor C_s behaves like a short circuit, therefore voltage across SCR is zero. With the passage of time, voltage across C_s builds up at a slow rate such that dv/dt across C_s and therefore across SCR is less than the specified maximum dv/dt rating of the device. Here the question arises that if C_s is enough to prevent accidental turn-on of the device by dv/dt , what is the need of putting R_s in series with C_s ?

Before SCR is fired by gate pulse, C_s charges to full voltage V_s . When the SCR is turned on, capacitor discharges through the SCR and sends a current equal to $V_s /$ (resistance of local path formed by C_s and SCR). As this resistance is quite low, the turn-on di/dt will tend to be excessive and as a result, SCR may be destroyed. In order to limit the magnitude of discharge current, a resistance R_s is inserted in series with C_s . Now when SCR is turned on, initial discharge current V_s/R_s is relatively small and turn-on di/dt is reduced.

In actual practice ; R_s , C_s and the load circuit parameters should be such that dv/dt across C_s during its charging is less than the specified dv/dt rating of the SCR and discharge current at the turn-on of SCR is within reasonable limits. Normally, R_s , C_s and load circuit parameters form an underdamped circuit so that dv/dt is limited to acceptable values. The design of snubber circuit parameters is quite complex. In practice, designed snubber parameters are adjusted up or down in the final assembled power circuit so as to obtain a satisfactory performance of the power electronics system.

FORMULA:-

$$dv/dt = \frac{0.632 V_s}{R_s C_s}$$

Where $R_s C_s$ is the snubber time constant.

$$R_s = \frac{V_s}{I_{TD}}$$

Where I_{TD} is the discharging current of the capacitor.

FUNCTION OF SNUBBER CIRCUITS:-

Protect semiconductor devices by:

- Limiting device voltages during turn-off transients.
- Limiting device currents during turn-on transients.
- Limiting the rate-of-rise of currents through the semiconductor device at device turn-on.
- Limiting the rate-of-rise of voltages across the semiconductor device at device turn-off.

CIRCUIT DIAGRAM:-

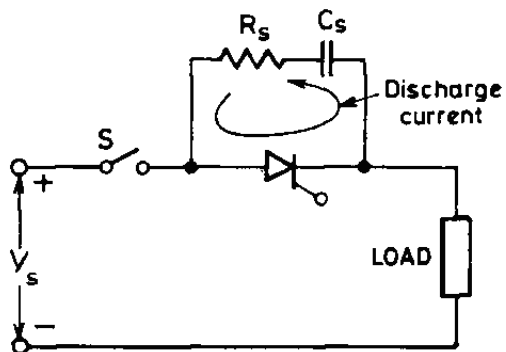

- PROCEDURE:-**
- (1) Switch s is turned on at $t=0$, a step voltage is applied across SCR. This voltage will have a high dv/dt . The value of snubber circuit component is calculated by using formula.
 - (2) When SCR is in forward blocking state the capacitor will charge.
 - (3) Therefore voltage across SCR will increase gradually. Thus the rate of change of voltage across SCR is reduced.
 - (4) When SCR is turned on the charged capacitor will discharge through resistance R and SCR. Thus R is limit the discharge current of the capacitor and prevents damage of SCR due to over current.

OBSERVATION TABLE:- For $dv/dt = \dots\dots\dots$

t =	VA

RESULT: - For given dv/dt ratings, design a snubber circuit by using the formula and observe the response of the circuit. Shown by the graph below

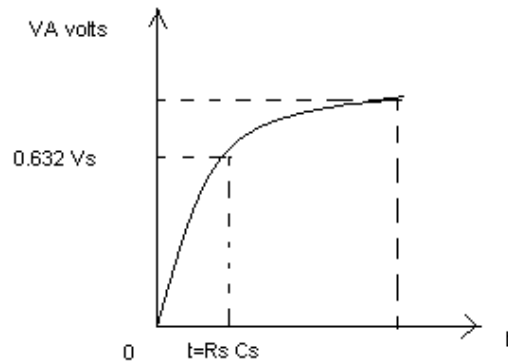

Variation in voltages across SCR after using the RC snubber circuit

- PRECAUTIONS: -**
- 1) All the connection should be tight.
 - 2) Ammeter is always connected in series in the circuit while voltmeter is parallel to the conductor.
 - 3) The electrical current should not flow the circuit for long time, Otherwise its temperature will increase and the result will be affected.
 - 4) It should be care that the values of the components of the circuit is does not exceed to their ratings (maximum value).
 - 5) Before the circuit connection it should be check out working condition of all the Component.

EXPERIMENT No- 8

OBJECTIVE: - Performance of SCR commutating circuits.

EQUIPMENT REQUIRED: - Experimental kit, DC power supply, CRO.

THEORY:- Commutation of SCR

It is the process to turn OFF conducting SCR. There are two ways of commutating an SCR.

- By reducing the forward current through the SCR below its holding current called as current commutation.
- By applying a large reverse voltage across the SCR called as voltage commutation.

Concept structure:

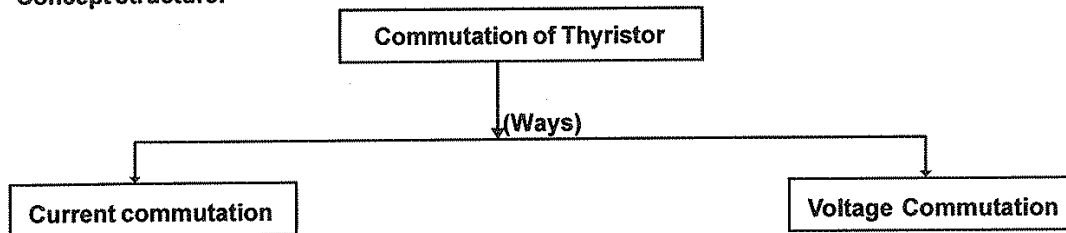

Types of commutation:

The two types of commutation

- **Natural Commutation :** When the thyristor is turned off due to its forward current going below holding current it is said to be naturally commutated. Natural commutation takes place in the circuits powered by an alternating supply.
- **Forced commutation :** When the thyristors operate on a pure DC input voltage, the forward current can not be reduced below holding current naturally. therefore the thyristors must be commutated 'forcibly' by using additional commutation circuit. This is called forced commutation. This external commutation circuit will turn off the SCR by either current or voltage commutation.

Classification of forced commutation methods

There are six different methods of forced commutation.

- **Class - A :** Self commutated by resonating load
- **Class - B :** Self commutated by LC circuit.
- **Class - C :** C or LC switched by another Load carrying SCR.
- **Class - D :** C or LC switched by an auxilliary SCR.
- **Class - E :** An external pulse source for commutation.
- **Class - F :** AC line commutation.

CIRCUIT DIAGRAM: - CLASS C COMMUTATION:

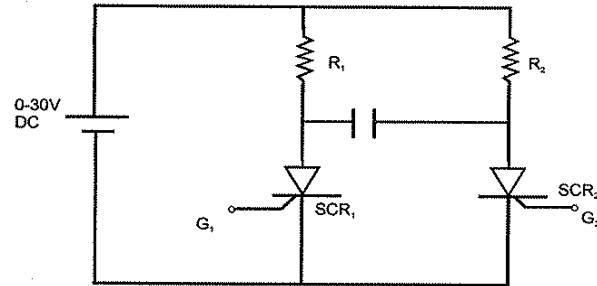

PROCEDURE:-

- Connect the circuit as shown in Figure.
- Connect G1 and G2 signals to gate of SCR.
- Switch ON the power supply.
- Connect oscilloscope across load resistance and observe waveforms.
- Draw the waveforms on graph paper.

OBSERVATION:-

SCR₁ and SCR₂ are capable of handling the load. C is the commutating capacitor and voltage across it is used to commutate the conducting SCR. Hence class C commutation is voltage commutation. F is load resistance

Concept Structure:

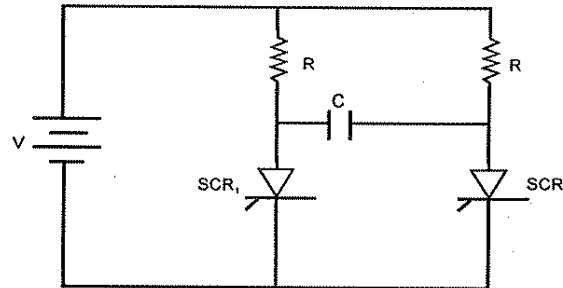

Proposition 5 : Modes of operation:

Before SCR₁ is triggered and SCR₂ is conducting

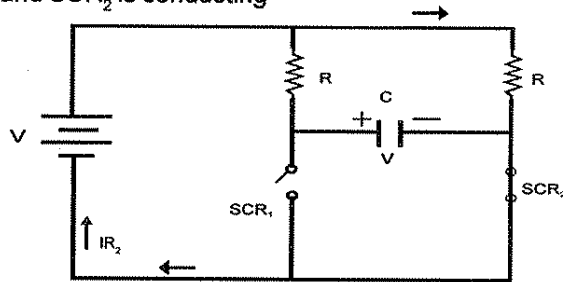

Fig. (a)

Mode I (t₀ to t₁)

At t₀ SCR₁ is triggered. Voltage across C reverse biases SCR₂ and it is turned off I_{R1} = V/R flows through SCR₁.

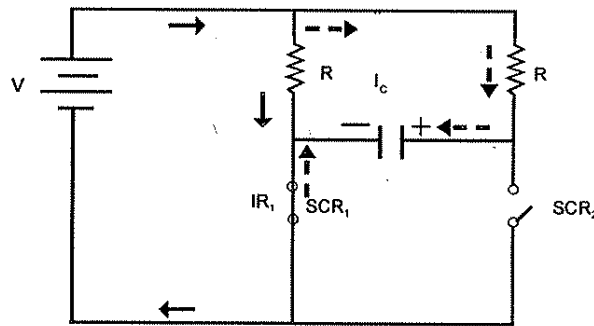

Fig. (b)

Mode II (t_1 to t_2)

At t_1 , $I_C = 0$ voltage across C = V with polarities as shown in Fig. (c) SCR₁ continues to conduct load current $I_{R1} = V/R$.

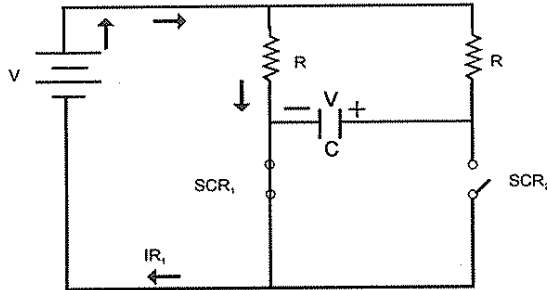

Fig. (c)

Mode III (t_2 to t_3)

At $t = t_2$, SCR₂ is turned ON. Commutating capacitor C applies reverse voltage across SCR₁ and turns it OFF. Current through SCR₂ = $I_{R2} + I_C$. At t_3 , capacitor is fully charged.

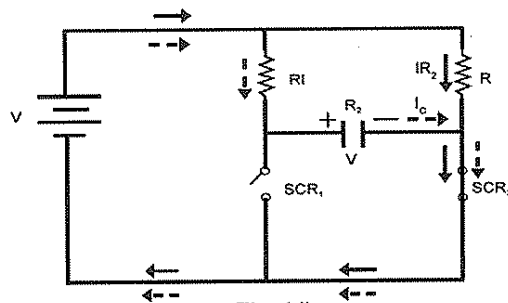

Fig. (d)

Mode IV (t_3 to t_4)

At $t = t_3$, SCR₁ capacitor is fully charged, $I_C = 0$ and $V_{SCR2} = V$. Voltage across C is constant with polarities as shown in Fig (e)

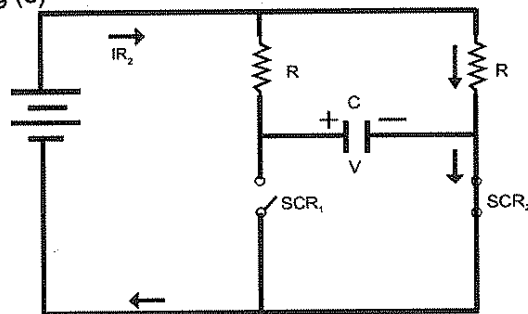
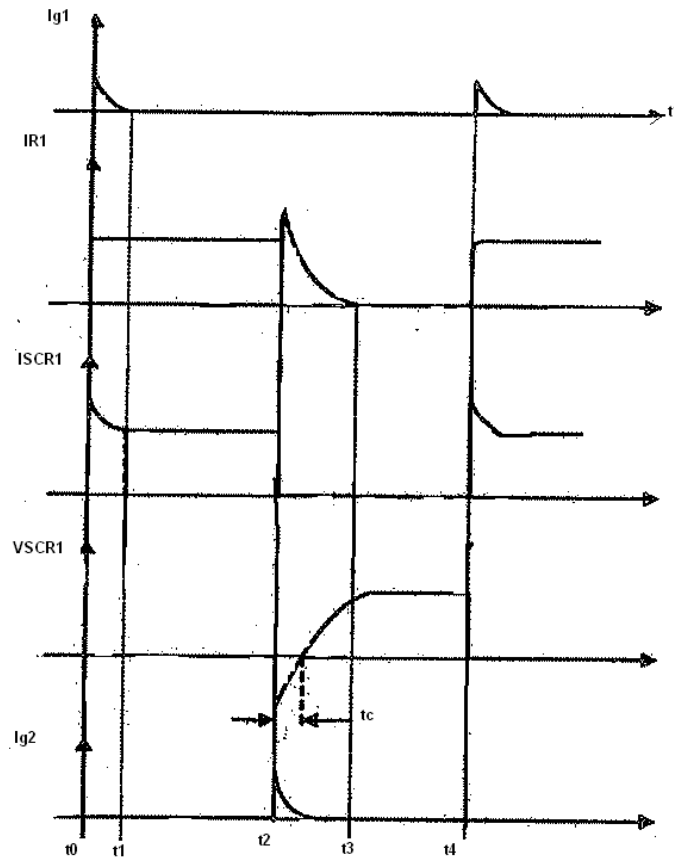

Fig. (e)

At $t = t_4$, SCR₁ is triggered again to turn OFF SCR₂ and the cycle of operation repeats itself

RESULT:- The waveforms for Class C commutation is determined.



- PRECAUTIONS: -**
- 1) All the connection should be tight..
 - 2) The electrical current should not flow the circuit for long time, Otherwise its temperature will increase and the result will be affected.
 - 3) It should be care that the values of the components of the circuit is does not exceed to their ratings (maximum value).
 - 4) Before the circuit connection it should be check out working condition of all the Component.

EXPERIMENT No- 9

OBJECTIVE: - Performance of Chopper circuit is using SCR.

EQUIPMENT REQUIRED: Basic power electronic trainer model, Resistor, D.C. power Supply, Multimeters.

THEORY:- Chopper circuits convert a fixed DC voltage at their input into variable DC voltage. In a rectifier circuit when we use diode, it gives the fixed DC output voltage, it is called uncontrolled rectifier. In place of diode if we use the thyristor, it gives the variable DC output voltage, it is called controlled rectifier. In controlled rectifier the o/p voltage is a function of firing angle (α) it means the voltage is vary according the value of ' α '. The shape of output wave depends on the type of load. For resistive load, the load current will have a rectangular shape and it will be in phase with the load voltage. The load current with the inductive load will be exponential in nature.

Basically, choppers are two types:

- 1) Step-down choppers: The load voltage can be controlled between 0 to V i.e. the output can at most be equal to the input.
- 2) Step-up choppers: The load voltage can be higher than the input dc voltage, V.

CIRCUIT DIAGRAM: -

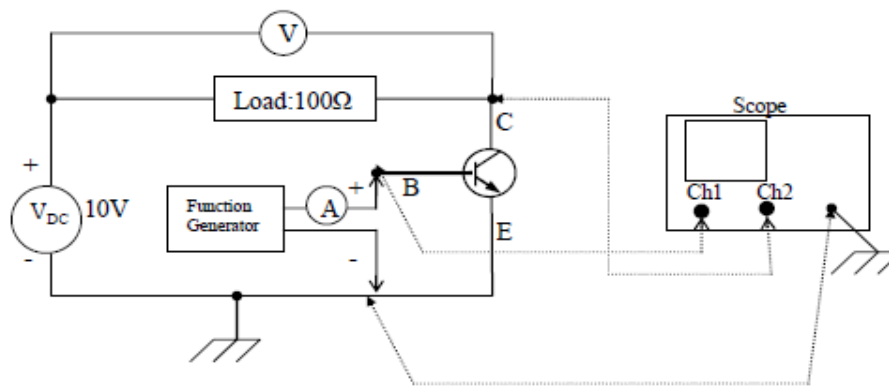

Fig.1: Basic Chopper Circuit

- PROCEDURE:**
1. Using an oscilloscope, set the function generator so that it produces a rectangular waveform with amplitude of 1.5 V and a frequency of 200 Hz.
 2. Connect the circuit shown in Fig. 1. Connect the +ve terminal of the function generator to the base of the BJT and the -ve to the ground. Connect Ch1 to B, Ch2 to the C and the ground of both channels to E.
 3. Set the output of the DC power supply to 10V and the current limit knob to max.
 4. Using the function generator, vary the duty cycle of the controlling signal. Plot the measured and calculated DC output voltages versus duty cycle (k).

OBSERVATION TABLE:-

Time setting:ms /div

Duty cycle K (%)	T (div)	t _{on} (div)	Measured V _{DC} output (V)	Calculated V _{DC} output (V)
80				
70				
60				
50				
40				
30				
20				

RESULT: - The waveforms are determined.

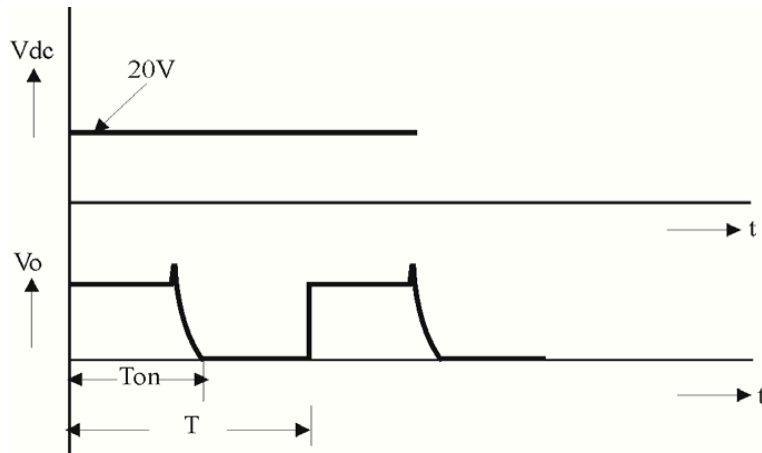

- PRECAUTIONS:** -
- 1) All the connection should be tight..
 - 2) The electrical current should not flow the circuit for long time, Otherwise its temperature will increase and the result will be affected.
 - 3) It should be care that the values of the components of the circuit is does not exceed to their ratings (maximum value).
 - 4) Before the circuit connection it should be check out working condition of all the Component.

EXPERIMENT No- 10

OBJECTIVE: -Performance of Parallel inverter using two thyristors.

EQUIPMENT REQUIRED: - Module, SCRs, Diodes, inductor, capacitors, etc.

THEORY:- Which device can convert DC power into AC power at desired voltage and frequency is called inverter. Center tapped transformer (due to this parallel inverter is also called a ⁴Center tapped inverter), two SCRs S1 and S2 are switched alternately, connect the I/P dc source, C is the commutation capacitor connected parallel with load (so it is called parallel inverter), L inductor are the component of parallel inverter.

The type of output waveform of parallel inverter is square in shape and it is independent of load. Inverters designed from BJT are preferable used in saturation region than active region because of high efficiency and high power output. :

Classification based on the power semiconductor device used:

- 1) Thyristor based inverter.
- 2) Transistor based inverter.
- 3) MOSFET based inverter.
- 4) IGBT based inverter.

Classification based on the configuration of the inverter:

- 1) Series inverter.
- 2) Parallel inverter.
- 3) Bridge inverter.

CIRCUIT DIAGRAM: -

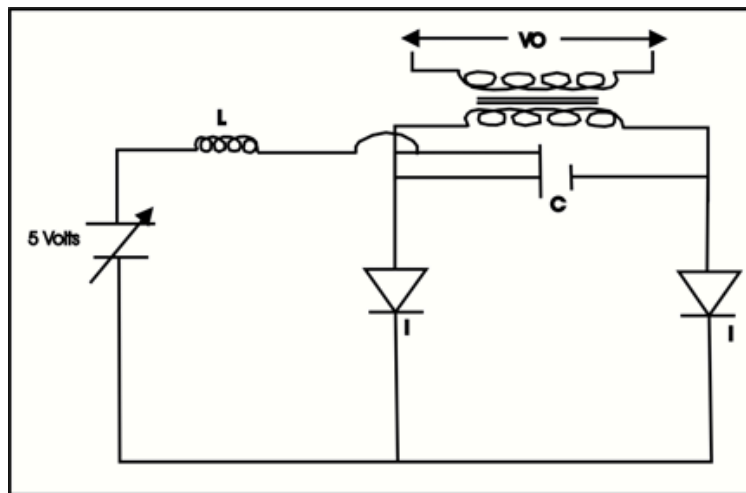

- PROCEDURE:** -
- 1) Connecting are made as show n in the circuit diagram.
 - 2) Select values of $c =$, $L =$
 - 3) Set input voltage to 5 volts.
 - 4) Apply trigger voltage, observe corresponding output voltage (ac voltage and wave form) at load terminal
 - 5) Note down the voltage & frequency of out put wave form.
 - 6) The o/p ac voltage is almost equal to the two times of the dc i/p voltage

OBSERVATION: - Note down the value of voltage and frequency. And draw the waveforms.

RESULT: - The waveforms are determined. The o/p ac voltage is almost equal to the two times of the dc i/p voltage

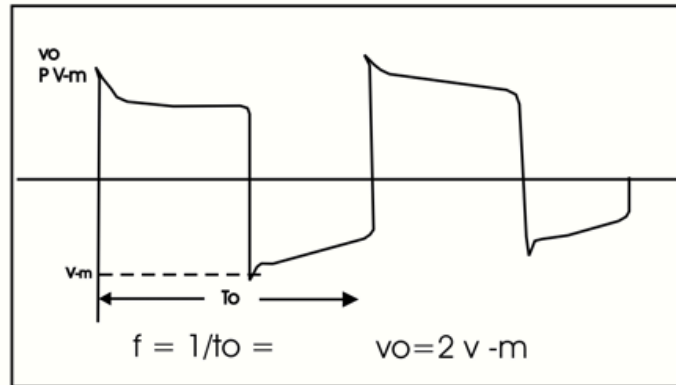

- PRECAUTIONS:** -
- 1) All the connection should be tight..
 - 2) The electrical current should not flow the circuit for long time, Otherwise its temperature will increase and the result will be affected.
 - 3) It should be care that the values of the components of the circuit is does not exceed to their ratings (maximum value).
 - 4) Before the circuit connection it should be check out working condition of all the Component.

EXPERIMENT No- 11

OBJECTIVE: - Study of Cycloconverter circuit using thyristors.

THEORY:- : A cycloconverter an AC waveform, such as the mains supply, to another AC waveform of other frequency. The word “cyclo” means frequency, so it is basically a frequency changer circuit. A device which converts input power at one frequency to output power at a different frequency with one stage conversion is called cycloconverter. They are most commonly used in three phase applications. In most power systems, the amplitude and the frequency of input voltage to a cycloconverter tend to be fixed values, whereas both the amplitude and the frequency of output voltage of a cycloconverter tend to be variable. The output frequency of a three-phase cycloconverter must be less than about one-third to one-half the input frequency.

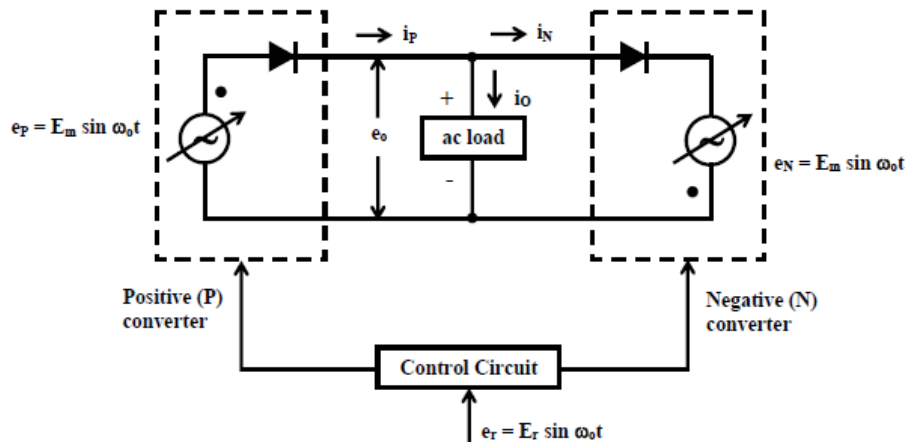

Equivalent circuit of cycloconverter

The basic principle of operation of a cyclo-converter is explained with reference to an equivalent circuit. Each two-quadrant converter (phase-controlled) is component obtained at its output terminals. The diodes connected in series with each voltage source, show the unidirectional conduction of each converter, whose output voltage can be either positive or negative, being a two-quadrant one, but the direction of current is in the direction as shown in the circuit, as only thyristors – unidirectional switching devices, are used in the two converters. Normally, the ripple content in the output voltage is neglected. The control principle used in an ideal cyclo-converter is to continuously modulate the firing angles of the individual converters, so that each produces the same sinusoidal (ac) voltage at its output terminals. Thus, the voltages of the two generators have the same amplitude, frequency and phase, and the voltage of the cyclo-converter is equal to the voltage of either of these generators. It is possible for the mean power to flow either ‘to’ or ‘from’ the output terminals, and the cyclo-converter is inherently capable of operation with loads of any phase angle – inductive or capacitive. Because of the uni-directional current carrying property of the individual converters, it is inherent that the positive half-cycle of load current must always be carried by the positive converter, and the negative half-cycle by the negative converter, regardless of the phase of the current with respect to the voltage. This means that each two-quadrant converter operates both in its rectifying (converting) and in its inverting region during the period of its associated half-cycle of current.

Types of cyclo-converter: - 1) Single-phase to Single-phase Cyclo-converter
2) Three-phase to Single-phase Cyclo-converter

Single-phase to Single-phase Cyclo-converter

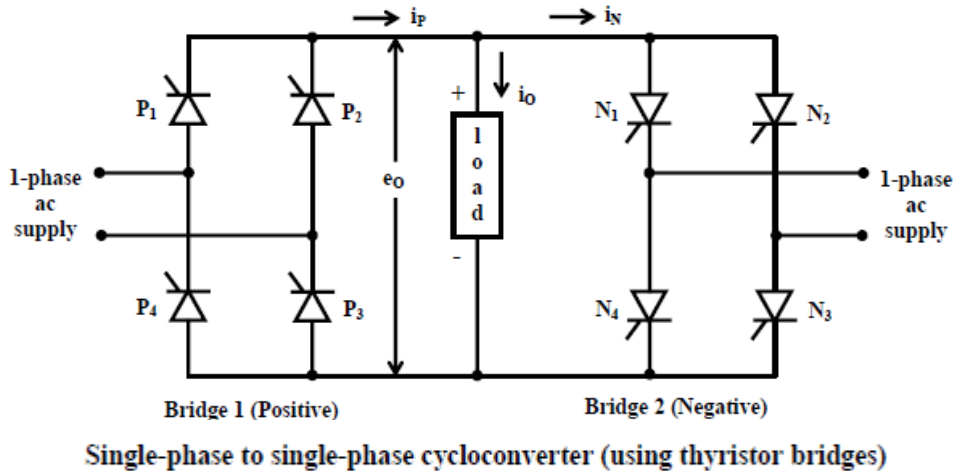

The circuit of a single-phase to single-phase cyclo-converter. Two full-wave fully controlled bridge converter circuits, using four thyristors for each bridge, are connected in opposite direction (back to back), with both bridges being fed from ac supply (50 Hz). Bridge 1 (P – positive) supplies load current in the positive half of the output cycle, while bridge 2 (N – negative) supplies load current in the negative half. The two bridges should not conduct together as this will produce short-circuit at the input. In this case, two thyristors come in series with each voltage source. When the load current is positive, the firing pulses to the thyristors of bridge 2 are inhibited, while the thyristors of bridge 1 are triggered by giving pulses at their gates at that time. Similarly, when the load current is negative, the thyristors of bridge 2 are triggered by giving pulses at their gates, while the firing pulses to the thyristors of bridge 1 are inhibited at that time.

WAVEFORM: - The waveforms for cycloconverter are observed.

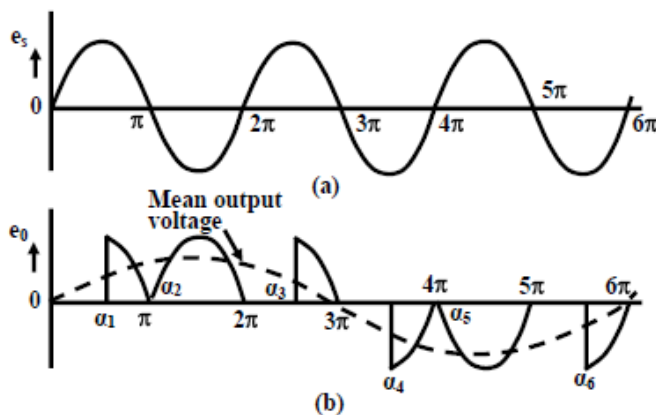

Input (a) and output (b) voltage waveforms of a cyclo-converter with (R) load

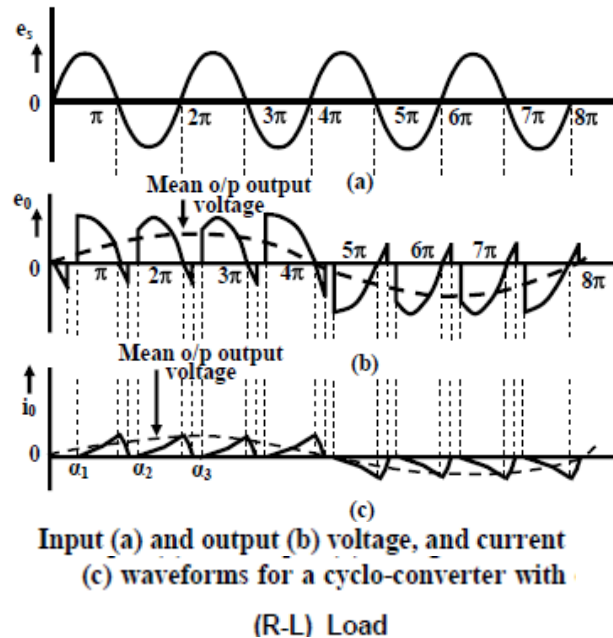

ADVANTAGES AND DISADVANTAGES OF CYCLO-CONVERTER:-

Advantages

1. In a cyclo-converter, ac power at one frequency is converted directly to a lower frequency in a single conversion stage.
2. Cyclo-converter functions by means of phase commutation, without auxiliary forced commutation circuits. The power circuit is more compact, eliminating circuit losses associated with forced commutation.
3. Cyclo-converter is inherently capable of power transfer in either direction between source and load. It can supply power to loads at any power factor, and is also capable of regeneration over the complete speed range, down to standstill. This feature makes it preferable for large reversing drives requiring rapid acceleration and deceleration, thus suited for metal rolling application.
4. Commutation failure causes a short circuit of ac supply. But, if an individual fuse blows off, a complete shutdown is not necessary, and cyclo-converter continues to function with somewhat distorted waveforms. A balanced load is presented to the ac supply with unbalanced output conditions.
5. Cyclo-converter delivers a high quality sinusoidal waveform at low output frequencies, since it is fabricated from a large number of segments of the supply waveform. This is often preferable for very low speed applications.
6. Cyclo-converter is extremely attractive for large power, low speed drives.

Disadvantages

1. Large number of thyristors is required in a cyclo-converter, and its control circuitry becomes more complex. It is not justified to use it for small installations, but is economical for units above 20 kVA.
2. For reasonable power output and efficiency, the output frequency is limited to one-third of the input frequency.
3. The power factor is low particularly at reduced output voltages, as phase control is used with high firing delay angle.

RESULT: - Study of cyclo-converter is completed.

EXPERIMENT No- 12

OBJECTIVE: - Study Time delay relay circuit using UJT and thyristor.

THEORY:- Some relays are constructed with a kind of "shock absorber" mechanism attached to the armature which prevents immediate, full motion when the coil is either energized or de-energized. This addition gives the relay the property of *time-delay* actuation. Time-delay relays can be constructed to delay armature motion on coil energization, de-energization, or both. Time-delay relay contacts must be specified not only as either normally-open or normally-closed, but whether the delay operates in the direction of closing or in the direction of opening. The following is a description of the four basic types of time-delay relay contacts

Time-delay relays are very important for use in industrial control logic circuits. Some examples of their use include:-

- 1) Flashing light control (time on, time off): two time-delay relays are used in conjunction with one another to provide a constant-frequency on/off pulsing of contacts for sending intermittent power to a lamp.
- 2) Engine autostart control: Engines that are used to power emergency generators are often equipped with "autostart" controls that allow for automatic start-up if the main electric power fails. To properly start a large engine, certain auxiliary devices must be started first and allowed some brief time to stabilize (fuel pumps, pre-lubrication oil pumps) before the engine's starter motor is energized. Time-delay relays help sequence these events for proper start-up of the engine.
- 3) Furnace safety purge control: Before a combustion-type furnace can be safely lit, the air fan must be run for a specified amount of time to "purge" the furnace chamber of any potentially flammable or explosive vapors. A time-delay relay provides the furnace control logic with this necessary time element.
- 4) Motor soft-start delay control: Instead of starting large electric motors by switching full power from a dead stop condition, reduced voltage can be switched for a "softer" start and less inrush current. After a prescribed time delay (provided by a time-delay relay), full power is applied.
- 5) Conveyor belt sequence delay: when multiple conveyor belts are arranged to transport material, the conveyor belts must be started in reverse sequence (the last one first and the first one last) so that material doesn't get piled on to a stopped or slow-moving conveyor. In order to get large belts up to full speed, some time may be needed (especially if soft-start motor controls are used). For this reason, there is usually a time-delay circuit arranged on each conveyor to give it adequate time to attain full belt speed before the next conveyor belt feeding it is started.

Time delay relays are built in these four basic modes of contact operation:-

- 1: Normally-open, timed-closed. Abbreviated "NOTC",
- 2: Normally-open, timed-open. Abbreviated "NOTO",
- 3: Normally-closed, timed-open. Abbreviated "NCTO",
- 4: Normally-closed, timed-closed. Abbreviated "NCTC",

1: Normally-open, timed-closed. Abbreviated "NOTC:- First we have the normally-open, timed-closed (NOTC) contact. This type of contact is normally open when the coil is unpowered (de-energized). The contact is closed by the application of power to the relay coil, but only after the coil has been continuously powered for the specified amount of time. In other words, the *direction* of the contact's motion (either to

close or to open) is identical to a regular NO contact, but there is a delay in *closing* direction. Because the delay occurs in the direction of coil energization, this type of contact is alternatively known as a normally-open, *on*-delay.

2: Normally-open, timed-open. Abbreviated "NOTO":- Next we have the normally-open, timed-open (NOTO) contact. Like the NOTC contact, this type of contact is normally open when the coil is unpowered (de-energized), and closed by the application of power to the relay coil. However, unlike the NOTC contact, the timing action occurs upon *de-energization* of the coil rather than upon energization. Because the delay occurs in the direction of coil de-energization, this type of contact is alternatively known as a normally-open, *off*-delay.

3: Normally-closed, timed-open. Abbreviated "NCTO":-Next we have the normally-closed, timed-open (NCTO) contact. This type of contact is normally closed when the coil is unpowered (de-energized). The contact is opened with the application of power to the relay coil, but only after the coil has been continuously powered for the specified amount of time. In other words, the *direction* of the contact's motion (either to close or to open) is identical to a regular NC contact, but there is a delay in the *opening* direction. Because the delay occurs in the direction of coil energization, this type of contact is alternatively known as a normally-closed, *on*-delay

4: Normally-closed, timed-closed. Abbreviated "NCTC":- Finally we have the normally-closed, timed-closed (NCTC) contact. Like the NCTO contact, this type of contact is normally closed when the coil is unpowered (de-energized), and opened by the application of power to the relay coil. However, unlike the NCTO contact, the timing action occurs upon *de-energization* of the coil rather than upon energization. Because the delay occurs in the direction of coil de-energization, this type of contact is alternatively known as a normally-closed, *off*-delay.

TIMING DIAGRAM:-

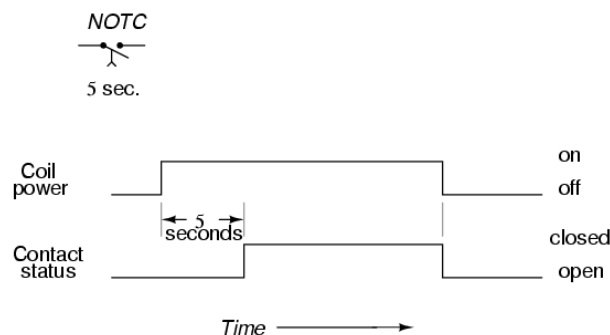
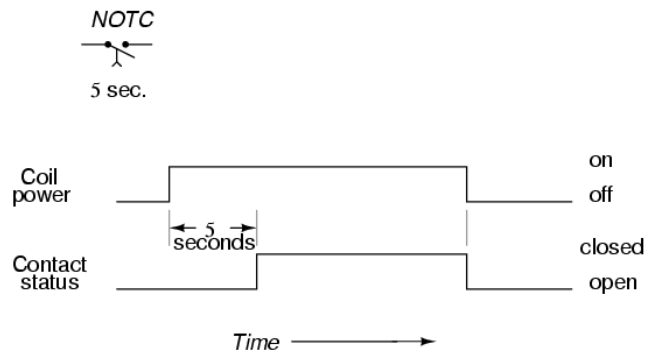

NCTO



5 sec.

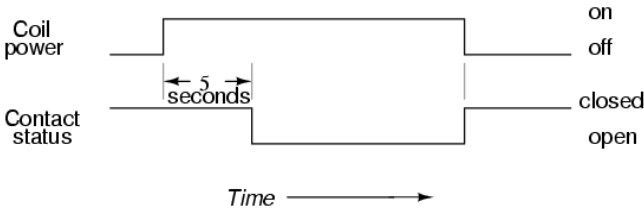

NCTC



5 sec.

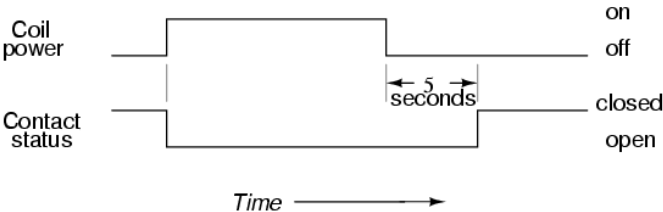

RESULT:- Study of Time delay relay circuit is completed.